

C型柵（汚水柵、雨水柵）

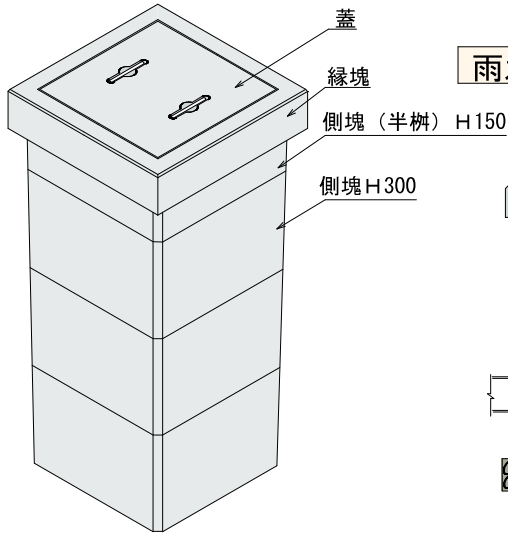

雨水柵施工例

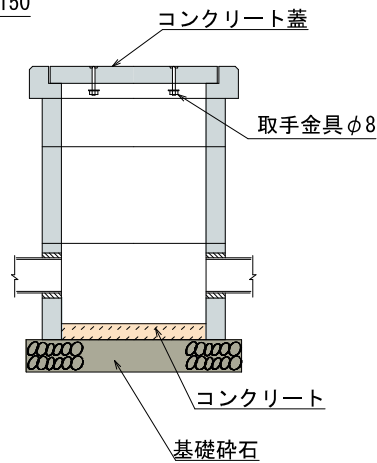

汚水柵施工例

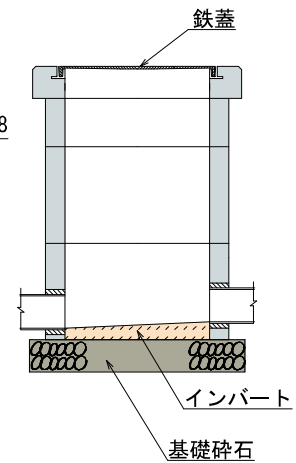

蓋

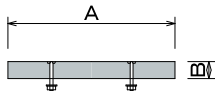

縁塊

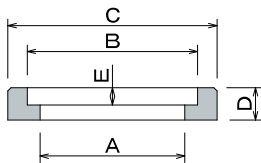

側塊

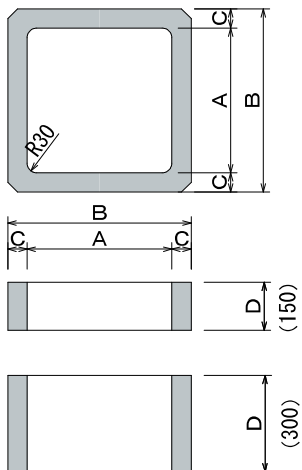

呼び名	寸法 (mm)					参考重量	
	A	B	C	D	E		
蓋	300	370	50	—	—	17	
	360	430	50	—	—	23	
	450	520	50	—	—	33	
	600	670	60	—	—	63	
縁塊	300	300	380	500	100	53	32
	360	360	440	560	100	53	36
	450	450	530	650	100	53	42
	600	600	680	800	100	63	55
側塊 (半柵)	300	300	400	50	150	—	25
	360	360	460	50	150	—	30
	450	450	570	60	150	—	43
	600	600	720	60	150	—	56
側塊	300	300	400	50	300	—	50
	360	360	460	50	300	—	58
	450	450	570	60	300	—	85
	600	600	720	60	300	—	115